



**TOWN OF EAST FISHKILL
ENGINEERING DEPARTMENT**

Water and Sewer Division

330 Route 376, Hopewell Junction, NY 12533

(845) 221-2428 Fax (845) 226-1924

<http://www.eastfishkillny.gov>

SEWER APPLICATION REQUIREMENTS

ALONG WITH THE COMPLETED APPLICATION, PLEASE PROVIDE THE FOLLOWING ITEMS:

- 2 COPIES OF THE SITE PLAN.
- LOCATION OF SEWER.
- INSURANCE FORMS FROM CONTRACTORS OR FOR "SELF" (See insurance info in permit application packet. Forms must be submitted with application. No faxing/emailing.)
- IF APPLICANT IS NOT THE HOME OWNER/PROPERTY OWNER, AN ORIGINAL, SIGNED, NOTARIZED LETTER FROM THE OWNER WILL BE REQUIRED GRANTING PERMISSION TO APPLY FOR PERMIT. (Applicant may obtain signature on application from owner, thus notarized letter not required.)
- FEE: PLEASE SEE THE CURRENT FEE SCHEDULE
CASH OR CHECK MADE OUT TO: TOWN OF EAST FISHKILL

THE OWNER/APPLICANT IS RESPONSIBLE FOR:
EXCAVATION, TAPPING INSTALLATION, AND RESTORATION IN ACCORDANCE WITH
TOWN CODE AND PLANS APPROVED BY THE ENGINEERING DEPARTMENT.

YOU WILL BE NOTIFIED BY THE BUILDING DEPARTMENT WHEN THE PERMIT HAS BEEN
PROCESSED.

WHEN YOU ARE READY FOR AN INSPECTION, YOU MUST SCHEDULE THE INSPECTION
WITH THE ENGINEERING DEPARTMENT @ 845-221-2428 AT LEAST 48 HOURS IN ADVANCE
OF EXCAVATION.



**TOWN OF EAST FISHKILL
ENGINEERING DEPARTMENT**

Water and Sewer Division

330 Route 376, Hopewell Junction, NY 12533

(845) 221-2428 Fax (845) 226-1924

<http://www.eastfishkillny.gov>

APPLICATION FOR SEWER SERVICE

OWNER/APPLICANT SHOULD BRING COMPLETED APPLICATION AND A CHECK FOR \$250.00 MADE OUT TO THE TOWN OF EAST FISHKILL AND TWO (2) COPIES OF THE SITE PLAN, A COPY OF NYS WORKERS' COMPENSATION AND CERTIFICATE OF LIABILITY TO THE ENGINEERING DEPARTMENT FOR APPROVAL

The undersigned, owner of the premises, Sec. _____ Blk. _____ Lot. _____, located on the _____ Side of _____ (Street), hereby requires permission to connect to the public sewer adjoining the premises. A check in the amount of \$ _____ is enclosed as an application fee. The fee covers the review of the plans and the inspection of construction. The applicant is responsible for excavation, tapping installation and restoration in accordance with Town Code and plans approved by the Engineering Department. A Site Plan must accompany the application.

The applicant will notify the Water & Sewer Operator's Business Office (VRI 845-677-3839), Building Department (845-221-2427) and Engineering Department (845-221-2428) at least 48 hours in advance of excavation to schedule the construction inspection.

Location of Sewer

Contractor

Owner/ Applicant

Mailing Address

Mailing Address

Telephone #

Telephone #

OFFICE USE ONLY

Engineer's Approval: _____

Date: _____

Site Plan (2 Copies) _____

Workers Comp/Liab. _____

Application: _____

Fee: \$ _____

Permit #: _____

Received and Taken in By: _____



TOWN OF EAST FISHKILL ENGINEERING DEPARTMENT

Water and Sewer Division

330 Route 376, Hopewell Junction, NY 12533

(845) 221-2428 Fax (845) 226-1924

<http://www.eastfishkillny.gov>

MINIMUM INFORMATION TO BE SHOWN OR NOTED ON THE PROPOSED DRAWING REGARDING SEWER SERVICE CONNECTIONS TO MUNICIPAL SEWER

1. A) If connecting to an existing sewer main or manhole:

Plans shall be prepared and signed and sealed by a New York State Licensed Professional Engineer or Registered Architect and submitted as part of the application.

- B) If connecting to an existing sewer stub:

A sketch shall be submitted as part of the application showing the layout of the proposed pipe work. Please Note: each application will be evaluated on a case by case basis and the Town of East Fishkill may require a stamped engineering plan to connect to a sewer stub.

2. Sewer service line shall be SDR 35 PVC and installed by a qualified Contractor familiar with this type of work.
3. Minimum slope on proposed sewer service line shall be 2.0%. Maximum slope 15%.
4. Minimum cover on proposed sewer service line shall be 3'-6" (4'-0" preferred). If this is not possible the owner/applicant shall contact the Town of East Fishkill Engineering Department prior to submitting drawings.
5. Heavy duty SDR 35 PVC fittings and couplings shall be used for the construction of the SDR 35 PVC sanitary sewer service.
6. Housetrap and fresh air vent detail and location.
7. Location and type of transition coupling, if applicable. Transition coupling from SDR 35 PVC to Cast Iron pipe shall be as manufactured by GPK Products, Inc. or approved equal. Transition couplings from Ductile Iron pipe to SDR 35 PVC shall be as manufactured by Romac "Style 501" straight barrel type, min. 10" length or approval equal.
8. TRENCH DETAIL: (Please see attached).
9. CLEAN OUT DETAIL: (Please see attached).

All changes in pipe alignment 45° or greater shall require a clean out. Clean outs shall be located at the property line and spaced no more than 50 feet on center. Clean out caps shall be screw type caps and cut flush to finished grade.

10. TIE IN DETAIL: (Please see attached). Required only for tie in to mains.
11. ROAD REPLACEMENT DETAIL: (Please see attached). Required only for work within pavement area.
12. The existing septic system shall be abandoned in accordance with the latest Dutchess County Department of Health Rules and Regulation.

13. Applicant shall show all existing utilities that may be in conflict with new service connection or that could be damaged during excavation operations and take necessary precaution to protect them. Contractor shall notify Town Engineer of any damage to existing utilities and repair them to the satisfaction of the appropriate authority
14. The contractor shall call in a “Code 53” prior to excavation for the sewer service connection installation. The Contractor shall protect all utility markings until construction is complete.
15. The contractor shall be responsible for notifying the Town of East Fishkill Water & Sewer Operator, Engineering Department, and division of Code Enforcement a minimum of 48 hours prior to commencement of work and 24 hours prior to requesting a construction inspection.
16. **A fee will be assessed if the connection is not ready for inspection when scheduled or if it needs to be re-inspected.**
17. The contractor shall be responsible for protecting all persons during construction from harm in accordance with all applicable codes, rules & regulation, standards and good practices.
18. The contractor shall provide proof of insurance as required by the Building Department prior to issuance of sewer connection permit.
19. All work shall be performed in accordance with applicable Federal, State, County and Local Codes, Rules and Regulations.
20. Additional information may be required upon review of submitted documents. Requirements are subject to change.

Please note in addition to the above:

The Owner/Applicant shall verify that the subject parcel is within the Hopewell Hamlet Sewer District.

The Owner/Applicant shall install a “Town Approved” water meter to the water source prior to connection if not currently connected to a municipal water supply.

If the parcel is not within a Town sewer district then the Owner must complete an Outside of Sewer District Agreement and submit a filed copy to the Town prior to Construction.

The Owner/Applicant shall be required to fill out and submit an application for sewer service with fee.

The Owner/Applicant shall be required to fill out and submit an application for building permit with fee when applicable.

The Owner/Applicant shall contact the Town of East Fishkill Department of Highways at 845-221-2681 as to the information required to acquire a utility permit for work within the Town Right of Way.

*****THE ABOVE IS SUBJECT TO CHANGE WITHOUT NOTICE*****



**TOWN OF EAST FISHKILL
ENGINEERING DEPARTMENT**

Water and Sewer Division

330 Route 376, Hopewell Junction, NY 12533

(845) 221-2428 Fax (845) 226-1924

<http://www.eastfishkillny.gov>

SANITARY SEWER NOTES

**CONTRACTOR SHALL VERIFY ALL ELEVATIONS AND INVERTS PRIOR TO
CONNECTION TO PUBLIC SANITARY SEWER MAIN.**

1. CONTRACTOR SHALL VERIFY ALL ELEVATIONS AND INVERTS PRIOR TO CONNECTION TO PUBLIC SANITARY SEWER MAIN.
2. PROPOSED SANITARY SEWER HOUSE SERVICE SHALL BE SET AT A MINIMUM SLOPE OF ¼" PER 1 FOOT (OR 2%).
3. EXISTING SEPTIC TANK SHALL BE ABANDONED IN ACCORDANCE WITH THE STANDARDS SET FORTH BY THE DUTCHESS COUNTY DEPARTMENT OF HEALTH.
4. SEPTIC TANK SHALL BE REMOVED OR ABANDONED IN PLACE. IF TANK IS TO BE ABANDONED IN PLACE, THE BOTTOM OF THE TANK MUST BE BROKEN/CRUSHED AND THE TANK FILLED COMPLETELY WITH SAND OR CRUSHED STONE.

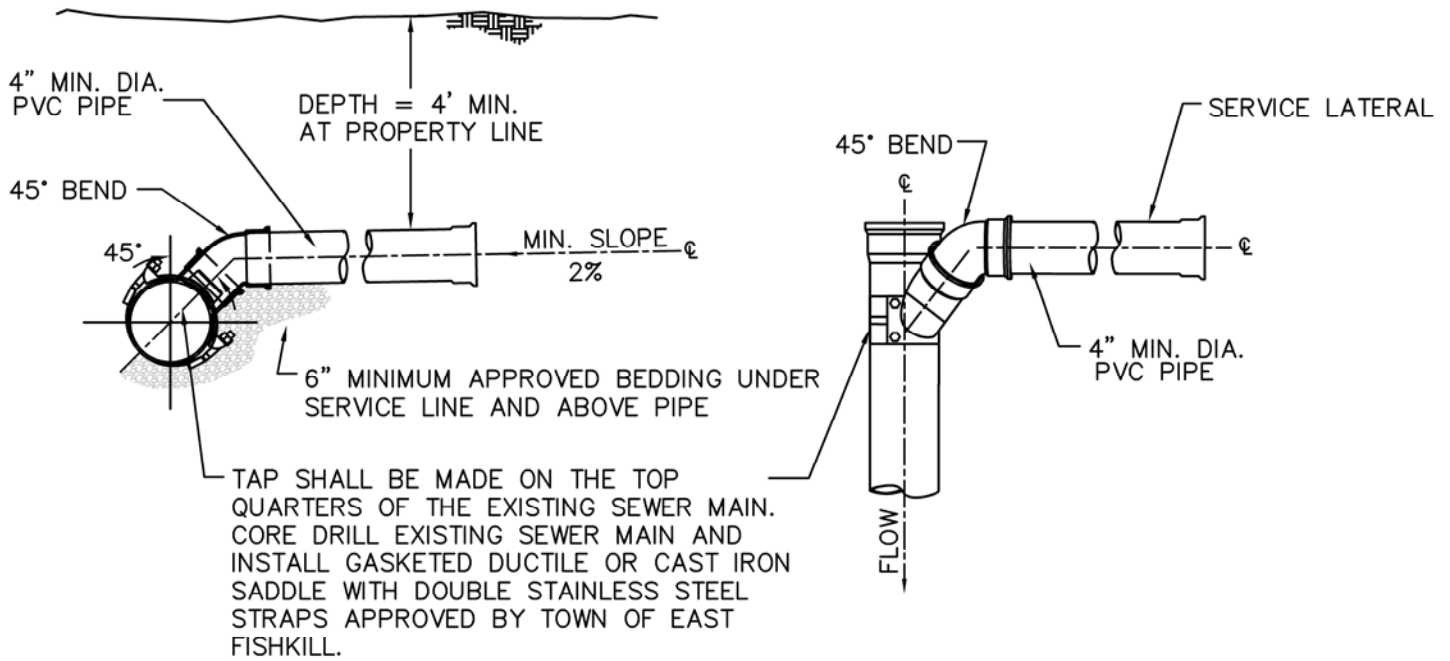

SECTION

PLAN

NOTES:

1. PROVIDE CLEANOUTS AS REQUIRED OR DIRECTED.
2. SADDLES SHALL BE INSTALLED IN ACCORDANCE WITH MANUFACTURER'S SPECIFICATIONS.
3. CONTRACTOR SHALL NOTIFY TOWN OF EAST FISHKILL 48 HOURS IN ADVANCE FOR INSPECTION.

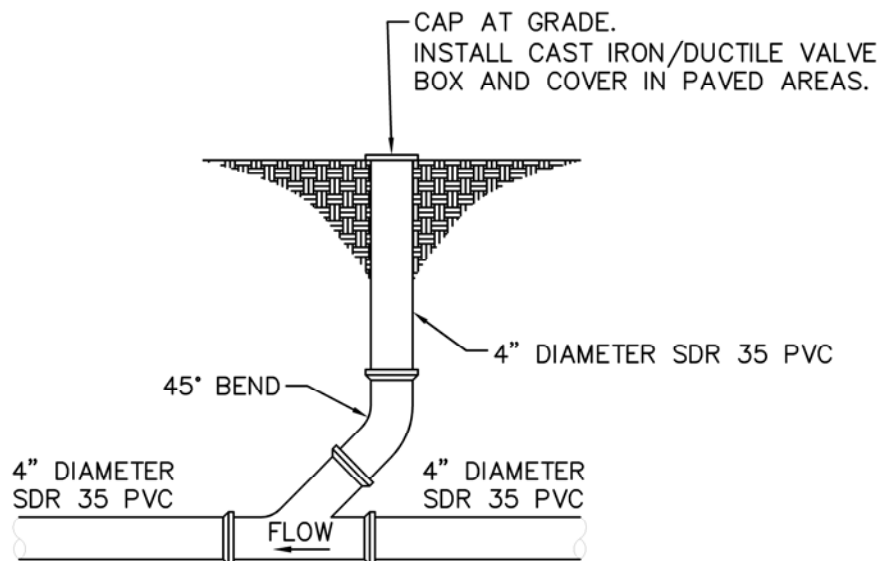

CLEANOUT

STANDARD SEWER LATERAL CONNECTION & CLEAN-OUT
NTS

4" MIN. TOPSOIL, SEED AND MULCH IN LANDSCAPED OR UNIMPROVED AREAS, OR FULL SECTION REPLACEMENT IN KIND IN IMPROVED AREAS. SEE PAVEMENT REPLACEMENT DETAIL.

PIPES SHALL BE BACKFILLED WITH SELECT FILL MATERIAL FROM 6" TO 24" ABOVE THE TOP OF THE PIPE. SELECT FILL SHALL CONSIST OF SOIL WITH NO STONES GREATER 2" IN DIAMETER. BACKFILL MATERIAL MAY CONTAIN STONES IN THEIR GREATEST DIMENSION FROM 24" ABOVE THE TOP OF THE PIPE TO THE BOTTOM OF THE SUBGRADE. ALL BACKFILL MATERIAL SHALL BE FREE OF ORGANIC AND FROZEN MATERIAL. PLACED IN 12" LIFTS (PRIOR TO COMPACTION) AND COMPACTED WITH A MECHANICAL TAMPER.

SEWER MAINS IN EASEMENTS AND PVC SEWER SERVICE LINES SHALL HAVE MAGNETIC LOCATOR TAPE LABELED "CAUTION SEWER LINE BELOW INSTALLED OVER NEW PIPE AT BOTH 12" AND 24" BELOW FINISHED GRADE OVER THE CENTERLINE OF THE PIPE

INITIAL BACKFILL HAND OR MACHINE PLACED LITTLE OR NO TAMPING REQUIRED ON TOP OF PIPE

12" R.O.B. GRAVEL
 6" MINIMUM
 SPRINGLINE
 HAUNCHING
 4" to 5" MINIMUM BEDDING

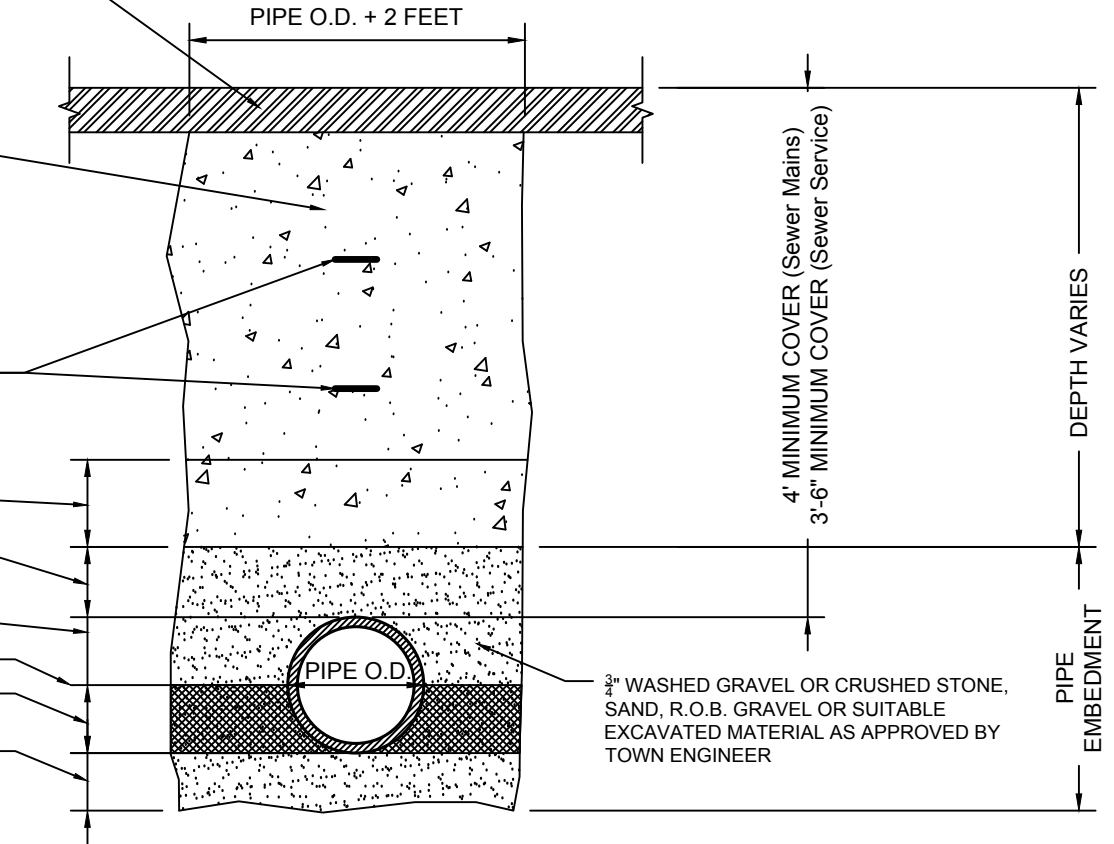

Typical Sanitary Sewer Trench Detail

N.T.S.

DEFLECTION OF PIPE AS PER MANUFACTURER'S RECOMMENDATIONS OR AS REQUIRED BY THE TOWN OF EAST FISHKILL

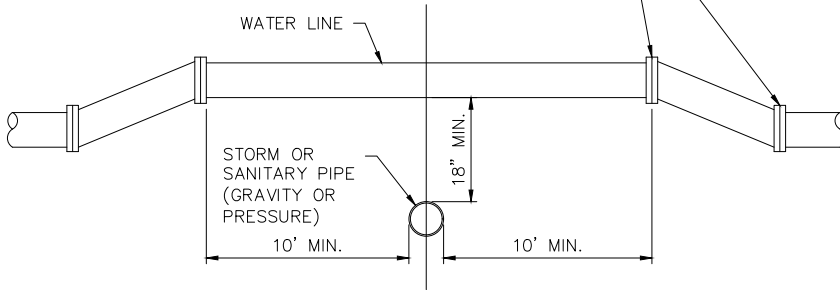

NOTE:
FOR ANY CONDITIONS OTHER THAN SHOWN AT THE LEFT, THE FOLLOWING REQUIREMENTS SHALL BE MET: THE JOINTS OF THE SANITARY SEWER OR STORM DRAIN SHALL BE A MINIMUM OF 10' FROM THE POINT OF CROSSING. THE SANITARY SEWER SHALL BE CLASS 150 PRESSURE PIPE AND THE STORM DRAIN SHALL BE LOCK-JOINT PRESSURE PIPE. WHERE THE ABOVE CONDITIONS CANNOT BE MET, THE DUTCHESS COUNTY DEPARTMENT OF HEALTH SHALL BE NOTIFIED AND THEIR APPROVAL SHALL BE REQUIRED.

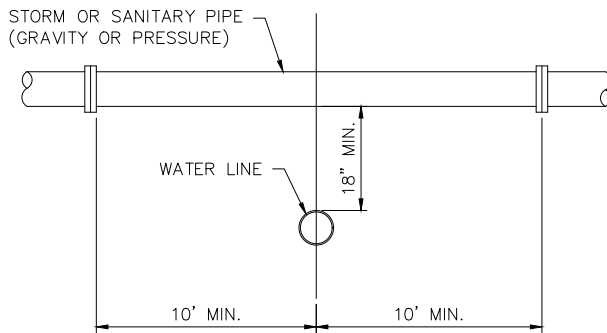

NOTE:
WHERE THE WATER LINE PASSES BENEATH THE SEWER LINE OR STORM DRAIN, THE JOINTS OF THE PIPE SHALL BE A MINIMUM OF 10' FROM THE POINT OF CROSSING. SEWER PIPE SHALL BE CLASS 150 PRESSURE PIPE AND THE STORM DRAIN SHALL BE LOCK-JOINT PRESSURE PIPE.

NOTE:
REQUIREMENTS AS STATED IN THE TWO CONDITIONS ABOVE WILL ALSO APPLY WHEN HORIZONTAL SEPARATION BETWEEN THE SEWER AND WATER IS LESS THAN 10' AND VERTICAL SEPARATION IS LESS THAN 18". WHERE THE ABOVE CONDITIONS CANNOT BE MET, THE DUTCHESS COUNTY DEPARTMENT OF HEALTH SHALL BE NOTIFIED AND THEIR APPROVAL SHALL BE REQUIRED.

CROSSING OF WATER LINE OVER AND UNDER SANITARY SEWER OR STORM DRAIN

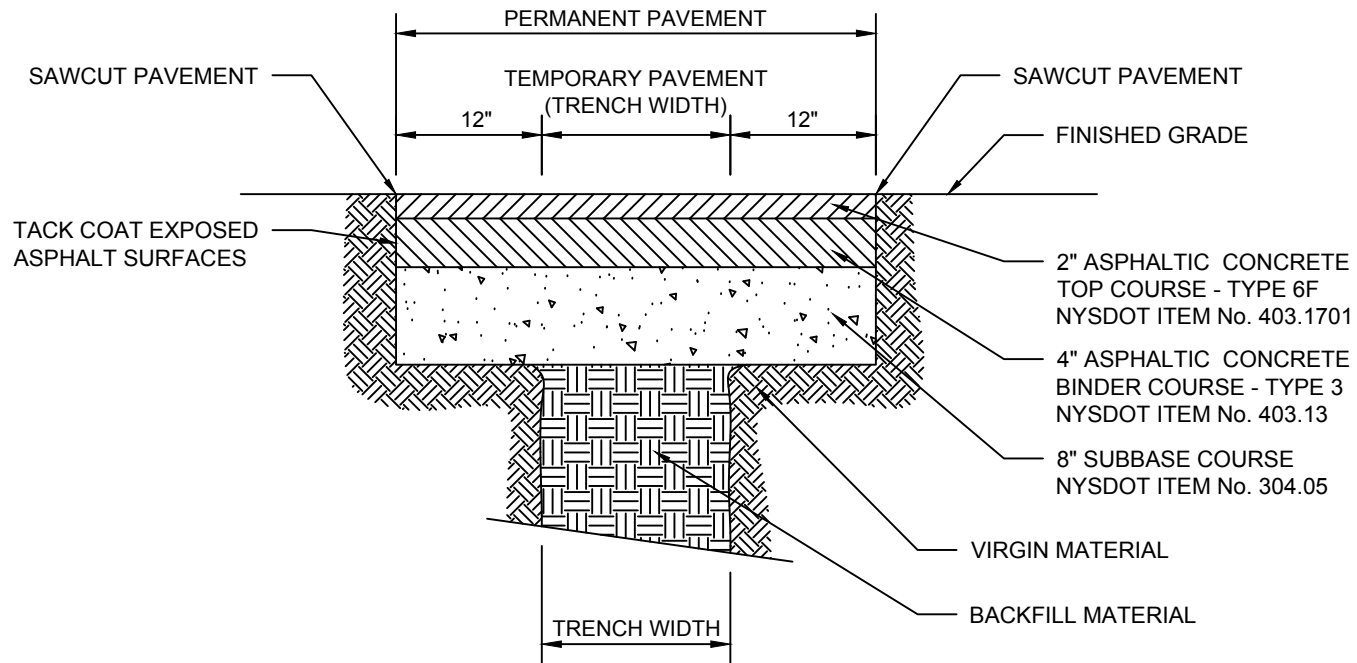

Pavement Replacement Detail

N.T.S.